

HeatMaster® 70 TC Evo



Combined gas fired condensing boiler & water heater
with stainless steel heat exchanger.



- > Heating and hot water from one unit saves space, reduces energy use and speeds up installation
- > Operates in most efficient mode (condensing) for both heating and hot water
- > Low maintenance with no anode protection required
- > Reduces legionella risk due to water stored at > 60°C
- > Corrosion-resistant stainless steel heat exchanger and tank reduces maintenance and increases system lifespan
- > Suited to high demand and critical hot water premises such as hotels and hospitals
- > Easy to use standardised controls using ACV Max control system
- > Combine with Evo S condensing boilers or Smart cylinder for highly efficient heating and hot water performance all from one manufacturer
- > Suitable for vented or unvented systems (optional Systempak 3 unvented kit required. Kit includes 25L expansion vessel, tundish, pressure control valve, combined pressure reducing valve and mounting bracket)
- > Supplied with LPG kit for simple on-site conversion
- > Supplied with factory fitted T&P relief valve
- > Improved access for service and maintenance
- > 5 year warranty*

Tank-in-tank technology

- > **Fast** heat up
- > **Rapid** recovery
- > **Reduced** footprint
- > **Reduced** scale
- > **Low** storage required
- > **Minimal** heat loss



ACV UK Ltd

St. David's Drive, St. David's Business Park, Dalgety Bay, Fife, KY11 9PF
uk.sales@acv.com | acv.com

Technical data and dimensions



Type	Unit	HM70TC Evo
Part number		XB550004
Input max (heating) HCV	kW	77.6
Input min (heating)	kW	21.5
Output power min (80/60°C) G20	kW	20.9
Output power max (80/60°C)	kW	68.0
Output at 100% (50/30°C) G20	kW	74.0
Efficiency at 100% load (80/60)	%	97.3
Efficiency at 100% load (50/30°C)	%	103.9
Efficiency at 30% load (EN15502-1) – nett	%	109.0
Seasonal space heating efficiency	%	96.6
Capacity (total)	L	315
Capacity (DHW)	L	190
Connection - heating	Ø"	1½ F
Connection - DHW	Ø"	1 M
Connection - gas	Ø"	¾ M
Flue connection	Ømm	100/150
Water pressure drop boiler at Δt = 20°C	mbar	9
Gas flow rate (max output)	m³/h	7.2
Weight (empty)	kg	298
Max operating temperature	°C	87
Max service pressure heating (primary)	bar	3
Max service pressure (DHW)	bar	8.6
Voltage	V	230
Pre-heating time from 10 to 80°C (Heat source: boiler)	min	27
Standby loss ΔT 30K	kWh/day	2.64
Standby loss ΔT 45K	kWh/day	3.94
Standby loss ΔT 30K	W	110
Standby loss ΔT 45K	W	164
Declared load profile		XXL
Water heating energy efficiency class		A
Space heating energy efficiency class		A
NOx class (EN15502)		6
NOx weighted (GCV) (EN15502)	mg/kWh	33.1
Sound power level indoors LWA (BSEN15036-1)	dB	60

Domestic hot water performance

Type	Unit	HM70TC Evo
Peak flow at 40°C	L/10'	716
Peak flow 1st hour at 40°C	L/60'	2455
Continuous flow at 40°C	L/h	2087
Peak flow at 45°C	L/10'	592
Peak flow 1st hour at 45°C	L/60'	2083
Continuous flow at 45°C	L/h	1789
Peak flow at 60°C	L/10'	348
Peak flow 1st hour at 60°C	L/60'	1391
Continuous flow at 60°C	L/h	1252

This data assumes an incoming mains water temperature of 10°C.

*In line with the recommendations specified in UK Building Regulations (2016) Part G, ACV UK Ltd advise the installation of a suitable domestic hot water thermostatic mixing valve on the hot flow immediately after the appliance.

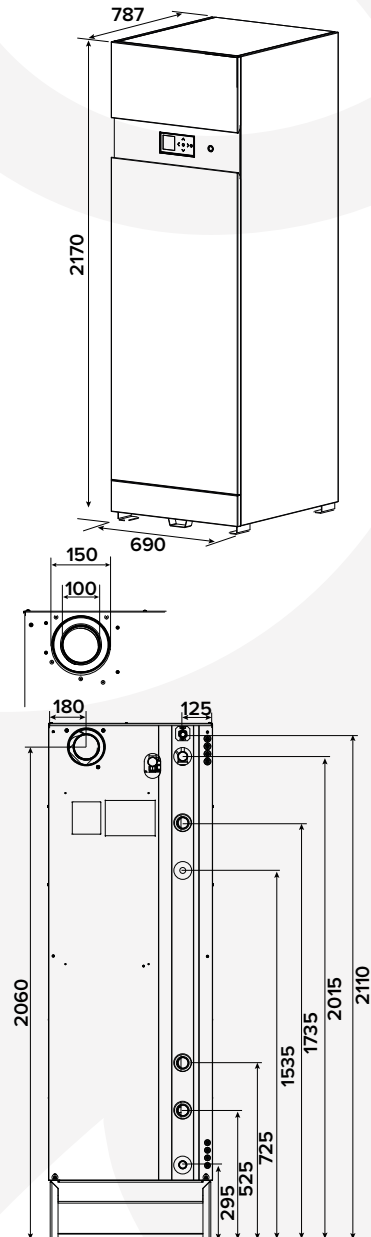

All dimensions in mm.

Clearances	(minimum)
Top	300mm
Left side	600mm
Right side	250mm
Rear	400mm