

# HeatMaster® 35 TC Evo



Combined gas fired condensing boiler & water heater  
with stainless steel heat exchanger.



- > Heating and hot water from one unit saves space, reduces energy use and speeds up installation
- > Operates in most efficient mode (condensing) for both heating and hot water
- > Low maintenance with no anode protection required
- > Reduces legionella risk due to water stored at > 60°C
- > Corrosion-resistant stainless steel heat exchanger and tank reduces maintenance and increases system lifespan
- > Suited to high demand and critical hot water premises such as hotels and hospitals
- > Easy to use standardised controls using ACV Max control system
- > Combine with Evo S condensing boilers or Smart cylinder for highly efficient heating and hot water performance all from one manufacturer
- > Suitable for vented or unvented systems (optional Systempak 3 unvented kit required. Kit includes 25L expansion vessel, tundish, pressure control valve, combined pressure reducing valve and mounting bracket)
- > Supplied with LPG kit for simple on-site conversion
- > Supplied with factory fitted T&P relief valve
- > Improved access for service and maintenance
- > 5 year warranty\*

## Tank-in-tank technology

- > **Fast** heat up
- > **Rapid** recovery
- > **Reduced** footprint
- > **Reduced** scale
- > **Low** storage required
- > **Minimal** heat loss



## ACV UK Ltd

St. David's Drive, St. David's Business Park, Dalgety Bay, Fife, KY11 9PF  
uk.sales@acv.com | acv.com

\*Terms & conditions available at [www.acv.com/gb/warranties](http://www.acv.com/gb/warranties).

# Technical data and dimensions



Type	Unit	HM35TC Evo
Part number		XB550002
Input max (heating) HCV	kW	38.7
Input min (heating)	kW	7
Output power min (80/60°C) G20	kW	6.8
Output power max (80/60°C)	kW	34.2
Output at 100% (50/30°C) G20	kW	36.4
Efficiency at 100% load (80/60)	%	98.0
Efficiency at 100% load (50/30°C)	%	103.9
Efficiency at 30% load (EN15502-1) – nett	%	109.0
Seasonal space heating efficiency	%	96.7
Capacity (total)	L	196
Capacity (DHW)	L	96
Connection - heating	Ø"	1 F
Connection - DHW	Ø"	1 M
Connection - gas	Ø"	¾ M
Flue connection	Ømm	80/125
Water pressure drop boiler at Δt = 20°C	mbar	6
Gas flow rate (max output)	m³/h	3.64
Weight (empty)	kg	177
Max operating temperature	°C	87
Max service pressure heating (primary)	bar	3
Max service pressure (DHW)	bar	8.6
Voltage	V	230
Pre-heating time from 10 to 80°C (Heat source: boiler)	min	26
Standby loss ΔT 30K	kWh/day	1.9
Standby loss ΔT 45K	kWh/day	2.98
Standby loss ΔT 30K	W	79
Standby loss ΔT 45K	W	124
Declared load profile		XXL
Water heating energy efficiency class		A
Space heating energy efficiency class		A
NOx class (EN15502)		6
NOx weighted (GCV) (EN15502)	mg/kWh	29.5
Sound power level indoors LWA (BSEN15036-1)	dB	60

## Domestic hot water performance

Type	Unit	HM35TC Evo
Peak flow at 40°C	L/10'	408
Peak flow 1st hour at 40°C	L/60'	1328
Continuous flow at 40°C	L/h	1104
Peak flow at 45°C	L/10'	339
Peak flow 1st hour at 45°C	L/60'	1127
Continuous flow at 45°C	L/h	946
Peak flow at 60°C	L/10'	197
Peak flow 1st hour at 60°C	L/60'	749
Continuous flow at 60°C	L/h	662

This data assumes an incoming mains water temperature of 10°C.

\*In line with the recommendations specified in UK Building Regulations (2016) Part G, ACV UK Ltd advise the installation of a suitable domestic hot water thermostatic mixing valve on the hot flow immediately after the appliance.

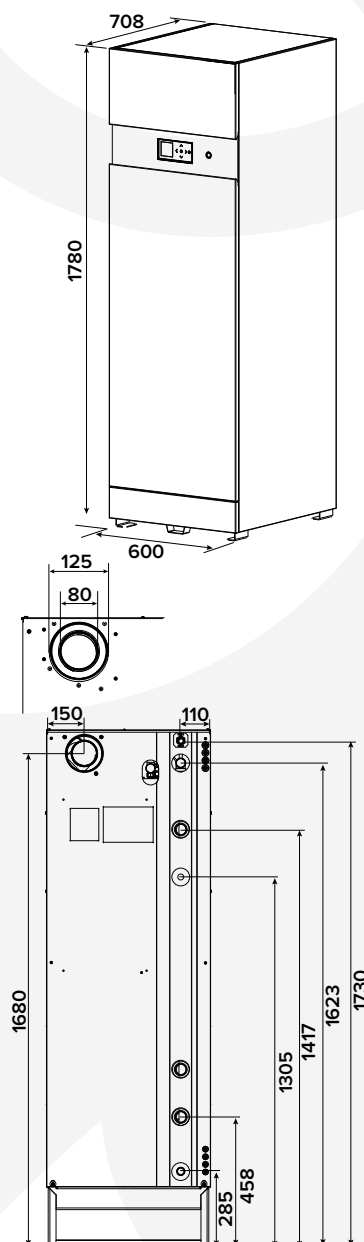

All dimensions in mm.

Clearances	(minimum)
Top	300mm
Left side	600mm
Right side	250mm
Rear	400mm