

Comfort

100 - 130 - 160 - 210 - 240



INSTALLATION, OPERATION & MAINTENANCE

Instructions for the User
and the Installer

GENERAL RECOMMENDATIONS.....	4
PRODUCT INFORMATION	5
Energy labelling	5
Environmental Protection.....	6
Rating Plate	6
APPLIANCE DESCRIPTION.....	7
Models - Comfort 100 - 130 - 160 - 210 - 240	7
TECHNICAL CHARACTERISTICS.....	8
Dimensions and Main Characteristics.....	8
Quality of Water	10
Performance	12
INSTALLATION	13
Safety Instructions.....	13
Packing Contents.....	15
Tools required for the installation.....	15
Tank Installation : COMFORT 100 - 130 - 160 -210 - 240.....	16
Available Kits and Accessories	18
G3 Requirements and Guidance (UK).....	18
Hydraulic Connections.....	20

STARTING UP23

Safety Instructions to Fill the Tank..... 23

Filling..... 24

Checks before Starting up..... 26

Starting Up procedure..... 26

MAINTENANCE27

Periodic Checks by the User 27

Annual Maintenance..... 27

Draining..... 28

Bringing back into Service after Maintenance..... 28

NOTES

This manual contains important information with respect to the installation, the starting up and the maintenance of the appliance.

This manual must be provided to the user, who will read it carefully and keep it in a safe place.

We accept no liability should any damage result from the failure to comply with the instructions contained in this technical manual.



Essential recommendations for safety

- It is strictly prohibited to carry out any modifications to the appliance without the manufacturer's prior and written agreement.
- The product must be installed by a qualified engineer, in accordance with applicable local standards and regulations.
- The installation must comply with the instructions contained in this manual and with the standards and regulations applicable to domestic hot water tanks.
- Failure to comply with the instructions in this manual could result in personal injury or a risk of environmental pollution.
- The manufacturer declines all liability for any damage caused as a result of incorrect installation or in the event of the use of appliances or accessories that are not specified by the manufacturer.



Essential recommendations for the correct operation of the appliance

- In case of anomaly, please call your installer for advice.
- Faulty parts may only be replaced by genuine parts.
- Our water heaters are designed and manufactured for the exclusive purpose of heating and storing domestic hot water.
- The domestic hot water heaters must only be heated using hot water in a closed circuit.



General remarks

- The availability of certain models as well as their accessories may vary according to markets.
- The manufacturer reserves the right to change the technical characteristics and features of its products without prior notice. Please check for an updated version of this manual on the website www.acv.com.
- The part number (P/N) and serial number (S/N) of the appliance are indicated on its rating plate and must be provided to ACV in case of warranty claim. Failure to do so will make the claim void.
- In spite of the strict quality standards that ACV applies to its appliances during production, inspection and transport, faults may occur. Please immediately notify your approved installer of any faults.

ENERGY LABELLING

PRODUCT FICHE

Groupe Atlantic Manufacturing Belgium

Rue Henry Becquerel, 1
7180 Senefte
BELGIUM



Product Model
Comfort 100
Comfort 130
Comfort 160
Comfort 210
Comfort 240

General purpose hot water storage tank







	Comfort				
	100	130	160	210	240
Energy efficiency class	C	C	C	C	C
Standing Loss *	56 W	62 W	69 W	75 W	78 W
Hot water storage volume	105L	130L	161L	203L	242L

* According to EN12897:2016

ENVIRONMENTAL PROTECTION

 The insulation of this equipment is made of PU foam containing R-1233zd gas, which is a fluorinated greenhouse gas.

RATING PLATE

 GAMB Rue Henry Becquerel 1 7180 Senefle BELGIUM www.acv.com Made in Belgium		Type: Comfort 130	
		P/N: 06631301 S/N: A198004	Prod. Date: 04-07-2026 Year: 2026
Measured acc. to EN 12897:2016			
Sanitary Operating Pressure		8,6 bar	 
Primary Operating Pressure		3 bar	
Maximum Design Pressure		10 bar	
Primary Heating Power Input		18 kW	
Primary Flow Rate		0,70 L/s	
Actual Capacity		75 L	
Standing Heat Loss		1,49 kWh/24h	
Maximum Sanitary Temperature		80°C	
Operating Voltage		230 V 50 Hz	
			
(21) A198004 (91) 06631301 (92) 2026			

MODELS - Comfort 100 - 130 - 160 - 210 - 240

"Comfort" is a floor-standing hot water storage tank that operates within a heating system. It is based on the ACV tank-in-tank design. This tank can also be installed vertically on a wall, using an optional mounting support.

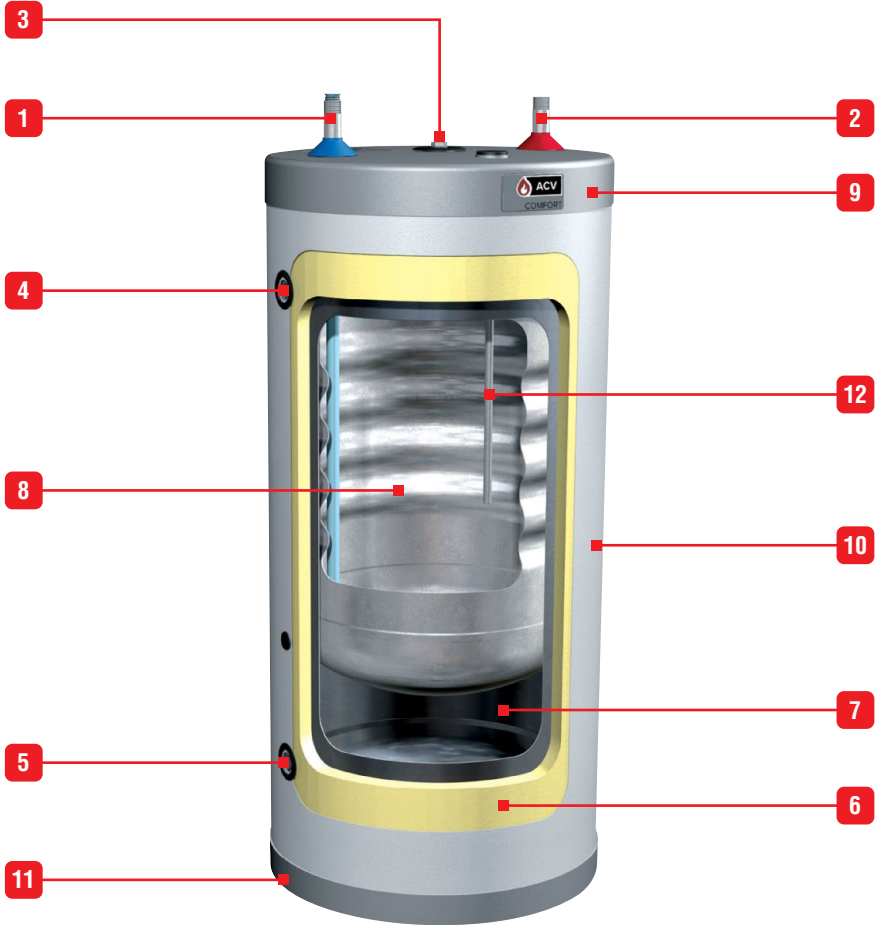

Key

- | | |
|--|-----------------------------------|
| 1. Cold water inlet | 7. Primary carbon steel tank |
| 2. Domestic hot water outlet | 8. DHW stainless steel tank |
| 3. Manual air vent valve | 9. Rigid polypropylene cover |
| 4. Primary fluid inlet | 10. External polypropylene casing |
| 5. Primary fluid outlet | 11. Rigid polypropylene base |
| 6. 30 mm of insulation in polyurethane | 12. Stainless steel dry-well |

DIMENSIONS AND MAIN CHARACTERISTICS

		Comfort				
Tank dimensions		100	130	160	210	240
A	mm	845	1005	1205	1475	1720
B	mm	580	740	940	1210	1455
C	mm	215	215	215	215	210
Empty weight	Kg	37	40	47	58	65

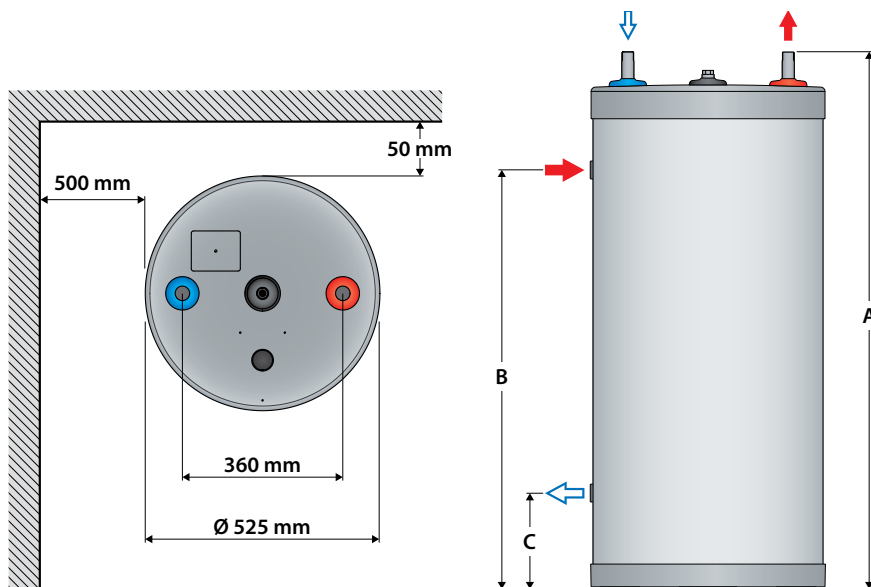

POSITION

The hot water tank must be installed in an area that is dry and protected from the elements.

Choose the most suitable location according to the position of the boiler and distance to the domestic hot water supply, in order to reduce temperature and pressure drops within the pipe work.



The unit should be positioned to allow the replacement, if required, of the dip tube and dry well during servicing.

The unit can be floor standing or wall mounted (using correct mounting kit available as an option).

Main characteristics		Comfort				
		100	130	160	210	240
Total capacity	L	105	130	161	203	242
Primary capacity	L	30	55	62	77	78
DHW capacity	L	75	75	99	126	164
Primary connection [F]	"	1	1	1	1	1
DHW connection [M]	"	3/4	3/4	3/4	3/4	3/4
Primary pressure drop*	mbar	19.6	22.4	23.5	40.6	46.5
Heating surface area	m ²	1.03	1.03	1.26	1.54	1.94
Max Design Pressure*	bar	10	10	10	10	10
Reheat Performance - Primary Heating Power Input*	kW	18.4	18.4	24.7	32.2	39.2
Primary flow rate (to achieve Reheat Performance) *	L/sec.	0.7	0.7	0.7	1.25	1.25
Reheat time*	min	10	10	10	9	9
Standing Heat Loss*	kWh/24h	1.34	1.49	1.66	1.80	1.87
	W	56	62	69	75	78

* According to EN12897:2016

Maximum Operating Conditions		Comfort				
		100	130	160	210	240
Max. operating pressure - primary	bar	3	3	3	3	3
Max. operating pressure - DHW	bar	8.6	8.6	8.6	8.6	8.6
Supply pressure (DHW circuit)	bar	6	6	6	6	6
Maximum temperature - heating side	°C	90	90	90	90	90
Maximum temperature - DHW side	°C	80	80	80	80	80

Water quality

See next page

QUALITY OF WATER

RECOMMENDATIONS FOR THE PREVENTION OF CORROSION AND SCALING

PRIMARY CIRCUIT

■ Influence of Oxygen and Carbonates in the Plant

Oxygen and dissolved gases in the water of the primary circuit contribute to the oxidation and the corrosion of the system components that are made of ordinary steel (radiators, heat exchanger of a boiler or water heater, tank, etc.). The presence of carbonates and carbon dioxide in the water leads to the formation of scale (carbonates) on the hot surfaces of the system, including the exchanger of the appliance. These deposits in the heat exchanger reduce the water flow rate and thermally insulate the exchange surfaces, which is likely to damage them.

■ Sources of Oxygen and Carbonates in the Plant

The primary circuit is a closed circuit; the water it contains is therefore isolated from the mains. When maintaining the plant or refilling the circuit, water renewal results in the addition of oxygen and carbonates in the primary circuit. The larger the water volume in the system, the larger the addition. Hydraulic components without oxygen barrier (e.g. PE pipes and fittings) also allow oxygen to enter the system.

■ Influence of Additives in the Plant

Depending on their design, primary circuits are sometimes subjected to a cold environment with sub-zero temperatures. The use of antifreeze products, particularly glycol-based products, is then necessary (see paragraph 8). It is advisable to limit the use of this type of additive to cases where it is necessary. These products degrade over time with heat, leading to the formation of acid by-products. This acidification of the primary water leads to corrosion and accelerated deterioration of the steel casing. The use of inhibited antifreeze (i.e. containing corrosion inhibitors) and special monitoring are therefore necessary.

■ Principles of Prevention

To protect your installation and prevent any risk of corrosion, it is important to check the characteristics of the water supplied to the appliance, as follows:

- Clean the existing circuits before installing a new appliance:
 - Before filling, the system must be cleaned in accordance with EN 14336. Chemical cleaning products may be used.
 - If the circuit is in poor condition, or the cleaning carried out is not effective, or the quantity of water in the installation is large (e.g. cascade), it is advisable to create a sealed primary system using hydraulic separation. It is also advisable to install a hydrocyclone or system filter on the plant side.
- Limit the refill frequency
 - Limit the number of fillings. To check the quantity of water introduced into the system, a water meter can be installed on the primary circuit filling connection.
 - Automatic filling systems are not recommended unless the fill frequency is monitored and the level of scale and corrosion inhibitors remain correct.
 - If your installation requires frequent water refilling, make sure your system is free of water leaks.
- Inhibitors may be used in accordance with EN 14868.

4. Limit the presence of oxygen and sludge in the water

- A deaerator (on the appliance supply line) and a dirt-separator (upstream of the appliance) must be installed, in accordance with the equipment manufacturers' specifications.*
- Using additives that regulate pH and/or inhibit corrosion and scale formation is also recommended.
- The additives must be used in accordance with the instructions issued by the manufacturer of the water treatment product.
- Use components that are designed to reduce and limit as much as possible the transfer of oxygen through the walls in the primary circuit. For example, PE pipes with an oxygen barrier.

5. Check water hardness and use softened water

- A water softener is recommended if the water hardness exceeds 20° fH (11.2° dH) (100 mg/l).
- Check the water hardness regularly and record the values.
- For very hard water, the softener will reduce hardness (by replacing calcium and magnesium with sodium), but the water will still have too high a conductivity. If necessary, demineralised water should be used.

Water hardness	°fH	°dH	mg/l CaCO ₃
Very soft	0 - 7	0 - 3,9	0 - 70
Soft	7 - 15	3,9 - 8,4	70 - 150
Fairly hard	15 - 25	8,4 - 14	150 - 250
Hard	25 - 42	14 - 23,5	250 - 420
Very hard	> 42	> 23,5	> 420

6. Check the characteristics of the water:

- Treat the water if the values of the parameters measured are out of tolerance.

Parameters	Target values
Acidity	7,0 < pH < 9,5
Hardness	< 20°fH (11,2°dH) (100 mg/l).
Conductivity	< 750 µS/cm (at 25°C)
Chlorides	< 150 mg/l
Iron	< 0,5 mg/l
Copper	< 0,1 mg/l
Dissolved oxygen	< 0,1 mg/l

7. Use demineralised water

- The use of demineralised water is recommended when filling new (or previously cleaned) systems, as it suppresses the problems associated with scale formation.
- By eliminating the presence of scale, the associated risks (sludge) are avoided and service life is increased.
- By definition, demineralised water has a very low conductivity. Corrosion kinetics are therefore considerably slowed down.
- On the other hand, demineralised water tends to become acidic (pH < 6). If the pH is too low, it is necessary to use additives to modify the pH and inhibit corrosion.

* In the UK, the installation of such equipment is strongly advised, as well as following the water treatment requirements set out in Guidance Notes on water treatment in central heating systems.

8. Observe the conditions of use prescribed by the propylene glycol supplier

- Consult the manufacturer to determine the compatibility of the antifreeze with the materials of the appliance.
- Using antifreeze in the primary circuit will reduce heating performance. The higher the antifreeze concentration, the lower the performance.
- If antifreeze is used in the primary circuit, it is particularly important that it is inhibited. The acidity (pH) of the water should be measured periodically to ensure that there is no gradual acidification.
- In case of problem of concentration or pH, follow the supplier's recommendations to adjust these parameters in order to avoid damaging the equipment (corrosion or accumulation of sludge).
- When the primary circuit is used to heat domestic hot water, the antifreeze must comply with public health regulations and be non-toxic. A food-grade propylene glycol is recommended. It should be diluted in the proportions recommended by the supplier, in compliance with local regulations.
- When using antifreeze is recommended, unless otherwise indicated by the product supplier, the proportion of antifreeze varies between 20% and 50%, in order to protect the plant effectively against corrosion and scaling
- Should there be a connection between a heat generator (e.g. boiler) and consumers (e.g. radiators or external water tank), a hydraulic separation is recommended between the heat generator circuit and the consumer circuit using a plate heat exchanger or similar.

9. Check that water softener is working properly

- A softener replaces calcium with sodium in the water to limit the formation of limescale. To do this, the softener must periodically regenerate its sodium reserve, using salt brine.
- When a softener is required to reduce water hardness, its operation must not cause corrosion problems.
- If the softener is of poor quality, is poorly maintained, suffers a technical breakdown or if a component deteriorates, salt could be released into the circuit. If salt is released back into the system, the chloride level will occasionally rise, creating the risk of corrosion.

DOMESTIC HOT WATER

■ Influence of Water Hardness

The presence of calcium and magnesium in the water causes scale deposits to build up in the system over the long term. These deposits appear on the hot spots of a storage tank, such as the electrical heating elements. But they also appear on the stainless steel casing when it comes into contact with the primary water. The effect of these deposits is to reduce the flow rate of water (through the I/O tubes) and to thermally insulate the heat exchange surfaces. Over time, they can lead to the formation of underdeposit corrosion, which causes damage.

■ Influence of Acidity, Chlorine and Chlorides

The stainless steel used for our stainless steel tanks has been specially selected for its corrosion-resistant properties. Particular care is taken during installation to preserve its properties. This intrinsic property comes from the passive layer that naturally protects stainless steel, working as a unique barrier.

Chlorine-based compounds (chlorine or chloride) are capable of destroying this protective barrier. Chlorine and chloride levels must therefore be carefully monitored to ensure that they do not exceed the values given in this document.

The acidity of the water (pH index) is a factor capable of accelerating the corrosion mechanisms described below. It is therefore important to maintain acidity within the ranges indicated in this document.

■ Principles of Prevention

To protect your plant and prevent any risk of corrosion, it is important to check the characteristics of the water supplied to the boiler. As a reminder, in the case of tap water, target values are indicated for a range of components in Water Supply (Water Quality) Regulations 2016. It is particularly important to:

1. Limit the presence of carbonates in water
 - A water softener is recommended if the water hardness exceeds 20° fH (11,2°dH) (100 mg/l).
 - Check water hardness regularly (see reference table on previous page).
2. Check the characteristics of water
 - Treat the water if the values of the measured parameters are out of tolerance.

Parameters	Target values
Acidity	6 < pH < 8
Hardness	< 20°fH (11,2°dH) (100 mg/l).
Conductivity	< 750 µS/cm (at 25°C)
Chlorides	< 150 mg/l
Chlorine	< 1 mg/l

3. Check that the water softener is operating correctly, as described in point 9 opposite.

PERFORMANCE

DHW performance*		Comfort				
		100	130	160	210	240
Peak flow at 45 °C	L/10'	182	202	275	348	469
Peak flow at 60 °C	L/10'	105	117	161	209	272
Peak flow 1st hour at 45 °C	L/60'	604	672	911	1156	1560
Peak flow 1st hour at 60 °C	L/60'	345	384	549	689	913
Constant flow at 45 °C	L/h	507	564	763	970	1309
Constant flow at 60 °C	L/h	288	320	465	576	769

* Conditions: Primary circuit temp.: 85°C - ΔT: 10°C - Water supply temp.: 10°C

SAFETY INSTRUCTIONS



General remarks

- Connections (electrical, hydraulic) must be carried out in accordance with applicable standards and regulations.
- If the water drawing off point is far from the tank, installing an auxiliary DHW loop can allow to get hot water more quickly at all times.



Essential instructions for the correct operation of the system

- The tank must be installed in a dry and protected area.
- Install the appliance to ensure easy access at all times.
- To avoid any risk of corrosion, connect the stainless steel tank directly to the earth. Use an adjustable earth clamp (see example below) on one of the DHW connections to connect to the earth. Advised copper wire section: 2.5mm².



- Make sure to install a pressure reducing valve set at 4.5 bar in the DHW circuit if the supply pressure is higher than 6 bar.
- On the DHW circuit, install an approved safety group, comprised of a safety valve set at 7 bar, a check valve and a stop valve.
- Make sure that the outlet of the safety unit goes directly to the sewer to avoid any potential damage.
- Do not install the safety group above the tank to avoid water discharge on to the tank.
- The installation of a domestic expansion vessel avoids discharge from the safety valve (loss of water).
- Capacity of domestic water vessels:
 - 5 Litres: for models 100- 130
 - 8 Litres: for models 160 - 210
 - 12 Litres: for model 240



Refer to the manufacturer's technical instructions on the expansion vessel for more details.



Essential instructions for the safety of persons and the environment

- **Hot water can burn!**
In the event of small amounts of hot water repeatedly being drawn off, a stratification effect can develop in the tank. The upper hot water layer may then reach very high temperatures.
- ACV recommends using a pre-set thermostatic mixing valve in order to provide hot water at a maximum of 60°C.
- Water heated to wash clothes, dishes and for other uses can cause serious burns.
- In order to avoid exposure to extremely hot water that can cause serious burns, never leave children, old people, disabled or handicapped people in the bath or shower alone.
- Never allow young children to turn on the hot water or fill their own bath.
- Adjust the water temperature in accordance with usage and plumbing regulations.
- The risk of developing bacteria exists, including “Legionella pneumophila”, if a minimum temperature of 60°C is not maintained in both the DHW tank and the hot water distribution network.



Essential instructions for the electrical safety

- Only an approved installer is authorized to carry out the electrical connections.
- Make sure that the appliance is connected to the earth.
- Install a 2-way switch and a fuse or circuit breaker of the recommended rating outside the appliance, so as to be able to shut power down when servicing the appliance or before performing any operation on it.
- Shut down external electrical supply of the appliance before performing any operation on the electrical circuit.
- This appliance is not intended for use by persons (including children) with reduced physical, sensory or mental capabilities, or lack of experience and knowledge, unless supervised or unless they have been given instruction concerning the use of the appliance by a person responsible for their safety.

PACKING CONTENTS

All appliances are delivered, tested and packaged separately.

Package

- One Comfort hot water tank.
- Multilingual Installation, Operation and Maintenance Instructions
- One Energy label

TOOLS REQUIRED FOR THE INSTALLATION

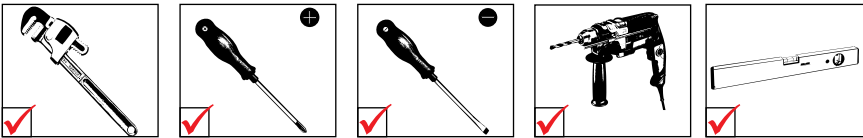
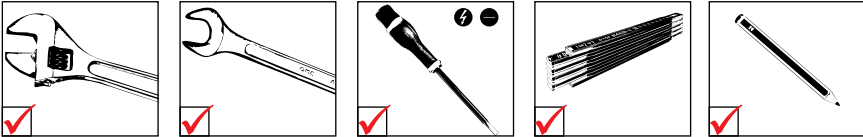

TANK INSTALLATION : COMFORT 100 - 130 - 160 -210 - 240

Floor mounting

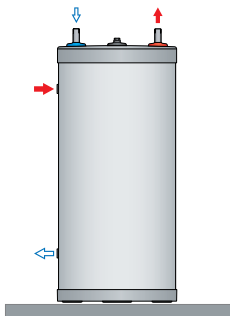

Horizontal wall hung position : domestic water connections on the right side

ACV does not recommend the installation in a horizontal position, as it will increase heat-up time and reduce DHW performances.

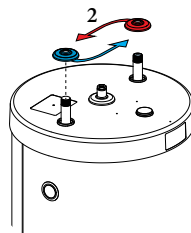
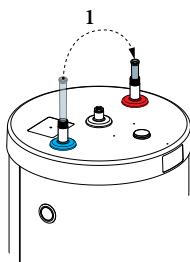
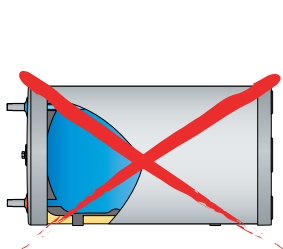
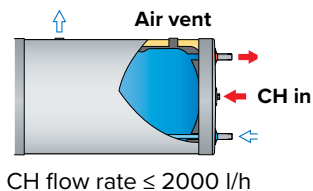
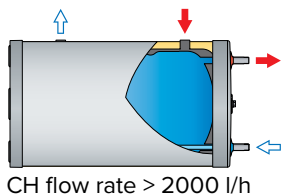

Vertical wall hung position : domestic water connections at the bottom side

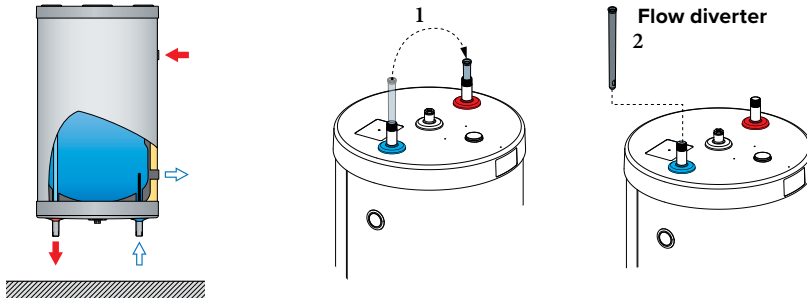

POSITION OF DHW SENSOR

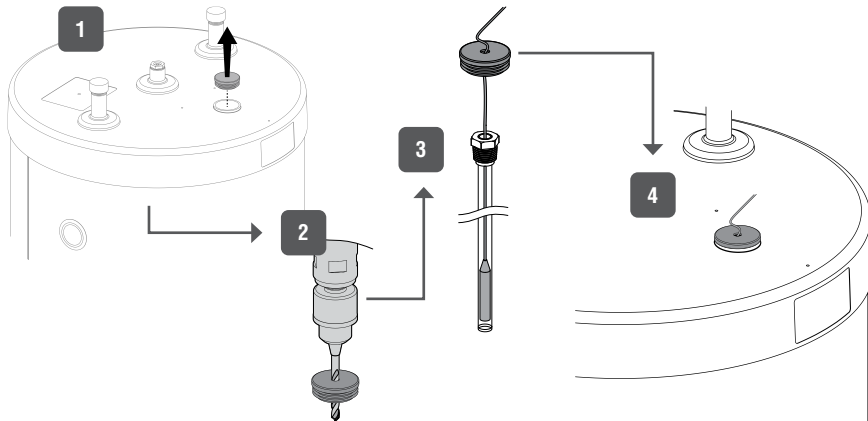

AVAILABLE KITS AND ACCESSORIES

DHW connection kit (code: 10800102)

- A. DHW temperature control valve
- B. Mixed domestic hot water outlet
- C. Cold water supply
- D. Drainage connection
- E. DHW expansion vessel connection
- S. Safety valve (10 bar)
- TH. Tank hot water outlet
- TC. Tank cold water inlet

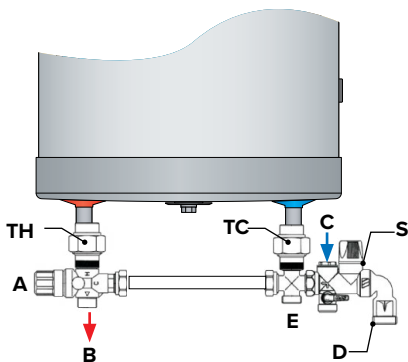
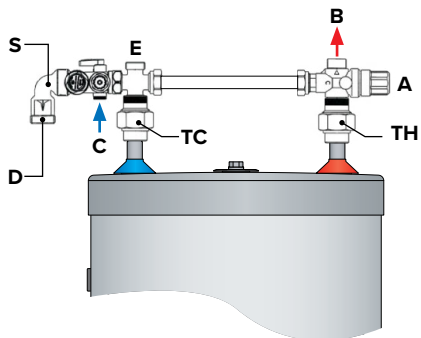

Thermostat control kit (60-80°) (code: A1002275)

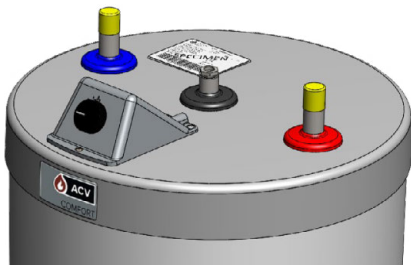

G3 REQUIREMENTS AND GUIDANCE - UK ONLY

Discharge pipe from safety valves

The *Building Regulation G3* requires that any discharge from an unvented system is conveyed to where it is visible, but will not cause danger to persons in or about the building.

The tundish and discharge pipes should be fitted in accordance with the requirements and guidance notes of Building Regulation G3. Please refer to the illustration below and to Building Regulation G3 for more information on pipe sizing and component locations.

For discharge pipe arrangements not covered by G3 Guidance advice should be sought from your local Building Control Officer.

Main characteristics :

- Any discharge pipe connected to the pressure relief devices (Expansion Valve and Temperature/Pressure Relief Valve) must be installed in a continuously downward direction and in a frost free environment.
- Water may drip from the discharge pipe of the pressure relief device.
- This pipe must be left open to the atmosphere.
- The pressure relief device is to be operated regularly to remove lime deposits and to verify that it is not blocked.



Essential recommendations for safety

- The temperature/pressure relief valve should only be replaced by a competent person.
- No control or safety valves should be tampered with or used for any other purpose.
- The discharge pipe should not be blocked or used for any other purpose.
- The tundish should not be located adjacent to any electrical components



The illustration below is an extract of *The Building Regulation G3*. Please refer to the source document for more information.

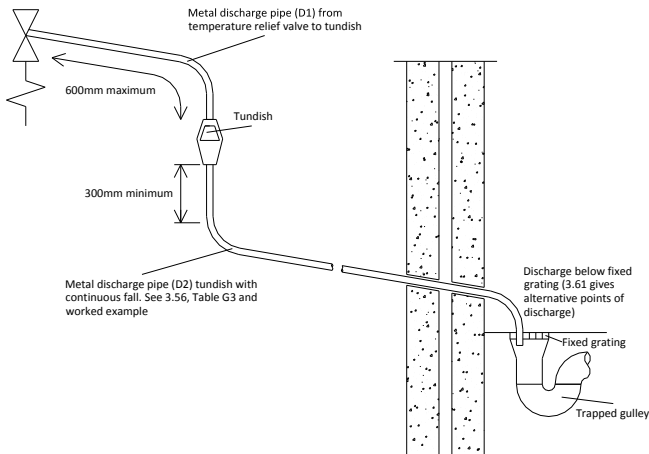

G3: Typical discharge pipe arrangement

CONNECTION



Essential instructions for the safety of persons and the environment

- Refer to the safety instructions for the installation. Failure to comply with these instructions can result in damages to the system, severe injuries or death.
- Hot water can burn! ACV recommends using a pre- set thermostatic mixing valve in order to provide hot water at a maximum of 60°C.



Essential instructions for the correct operation of the system

- The filling circuit of the DHW tank must be equipped with a safety group, comprised at least of a stop valve, a check valve, a safety valve set at 7 bar, and possibly, an expansion vessel of the appropriate size. Make sure that the circuit between the tank and the safety valve is always open.
- The third DHW tank connection, if any, can be used for the auxiliary DHW loop. If the connection is not used, replace the protective plug by a brass plug of the appropriate size.



General remarks

- In certain countries the domestic kits must be approved.
- The circuit illustrations are basic principle diagrams only.

CONNECTION TO THE DHW CIRCUIT (Typical wall installation)

Key

1. Filling valve
2. Pressure reducing valve (set at 4.5 bar)
3. Check valve
4. Stop valve
5. DHW expansion vessel
6. Pressure gauge
7. Safety valve (set at 7 bar)
8. Drain valve
9. Grounding
10. Stop valve
11. Thermostatic mixing valve
12. Hot water outlet

— — — Cold water
 — Hot water

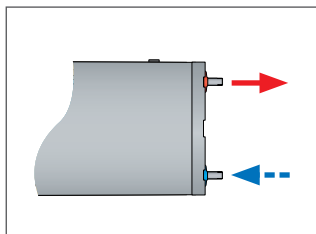

Horizontal installation

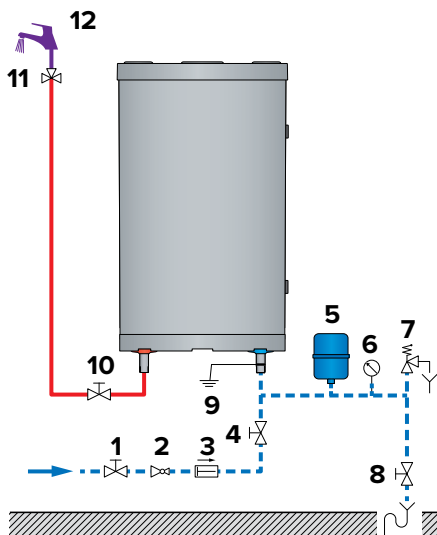

Vertical installation

CONNECTION TO THE DHW CIRCUIT (Typical floor installation)

Key

1. Filling valve
2. Pressure reducing valve (set at 4.5 bar)
3. Check valve
4. Expansion vessel
5. Safety valve (set at 7 bar)
6. Drain valve
7. Hot water outlet
8. Pressure gauge
9. Grounding
10. Stop valve
11. Thermostatic mixing valve

— Cold water
— Hot water

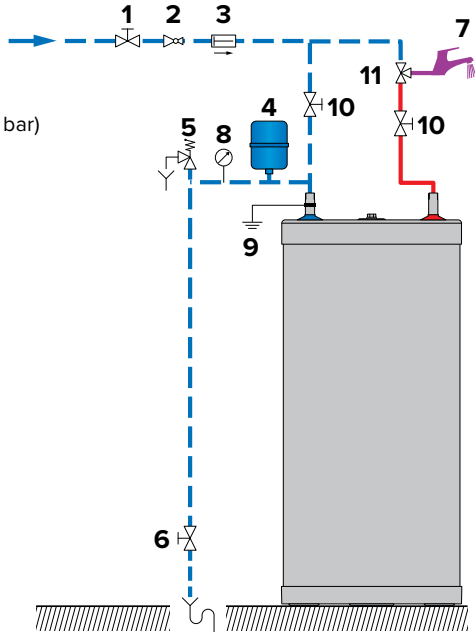

CONNECTION TO THE PRIMARY CIRCUIT (Typical floor installation)

Key

1. Primary circuit filling valve
2. Charging pump
3. Check valve
4. Primary circuit stop valve
5. Expansion vessel
6. Pressure gauge
7. Safety valve
8. Drain valve
9. Stop valve

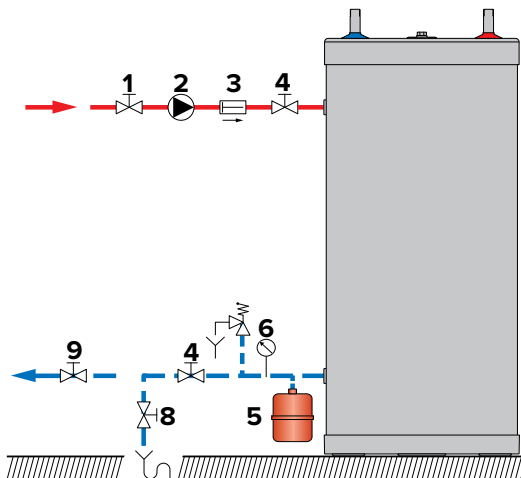

CONNECTION TO THE PRIMARY CIRCUIT (Typical wall installation)

Key

1. Primary circuit filling valve
2. Charging pump
3. Check valve
4. Primary circuit stop valve
5. Expansion vessel
6. Pressure gauge
7. Safety valve
8. Drain valve
9. Stop valve

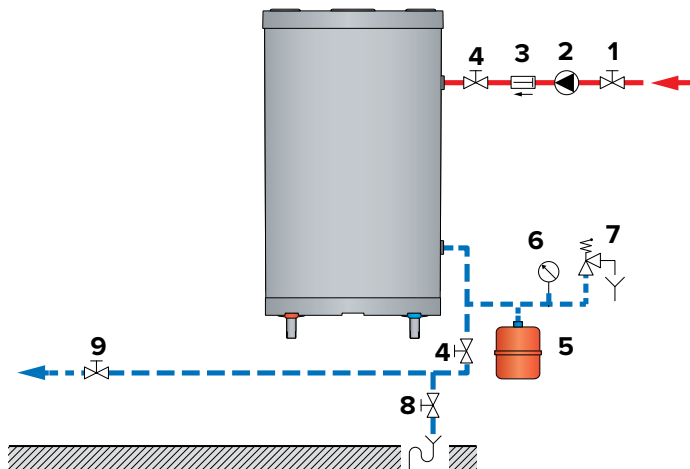

Vertical installation

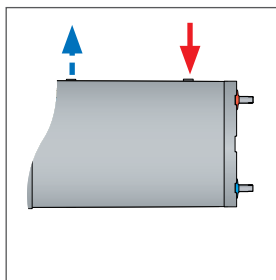

Horizontal installation

SAFETY INSTRUCTIONS TO FILL THE TANK



Essential instructions for the safety of persons and the environment

- The DHW tank must always be filled and pressurised before filling and pressurising the primary circuit.
- Do not use vehicle antifreeze. This can cause serious injury or death, or damage facilities.
- If antifreeze is needed in the primary circuit, it must comply with Public Hygiene Regulations and must be non-toxic. A food-grade Propylene Glycol is recommended. It must be diluted according to the ratio recommended in the local regulations.
- Consult the manufacturer to determine the compatibility of the antifreeze with the tank's construction materials.



Essential instructions for the correct operation of the system

- Before bringing the tank into service, check the connections to avoid any risk of leaks during filling.
- Only use drinking water to check that the DHW tank is watertight. The on-site test pressure must not exceed a pressure surge of 8,6 bar.
- Using antifreeze in the primary circuit will lead to a reduction in the heating performance. The higher the concentration of antifreeze in the circuit, the lower the performance.

FILLING



Essential instruction for the correct operation of the system

- The DHW tank must always be filled and pressurised before filling and pressurising the primary circuit.

FILLING THE DHW TANK (Figure 1)



General remark

- Connect the safety valve outlet to the sewer.
1. To fill the tank, open a hot water tap (2) located at the highest point of the system. It enables to bleed the air from the system.
 2. Open the filling valve (1) and the stop valves (3) to fill the DHW tank.
 3. Close the hot water tap (2), after the water flow has stabilised and the air has been completely evacuated.
 4. Check all the connections of the system for leaks.

FILLING THE PRIMARY CIRCUIT (Figure 2)



General remark

- If the tank is used within a heating system, refer to the heating boiler manual.
1. Check that the drain valve (3) of your primary circuit is tightly closed.
 2. Open the stop valves (1) and (2) of the primary circuit connected to the heating boiler.
 3. Open the air bleed valve (4) located on the top of the hot water tank.
 4. When the air is eliminated, close the air bleed valve (4). Make sure the air bleed valve is tight.

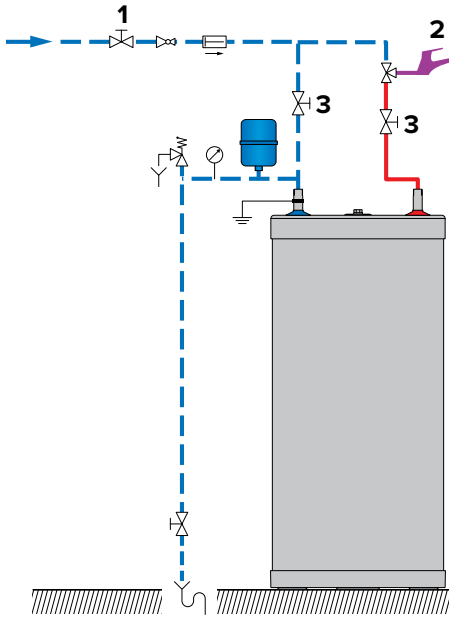
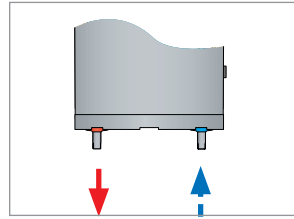
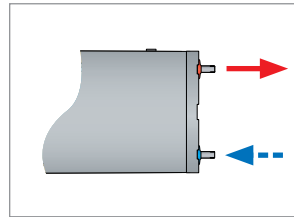

Figure 1

— Cold water
— Hot water



Vertical installation
on a wall



Horizontal installation
on a wall

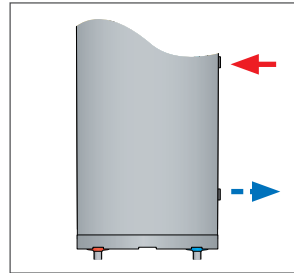

Vertical installation
on a wall

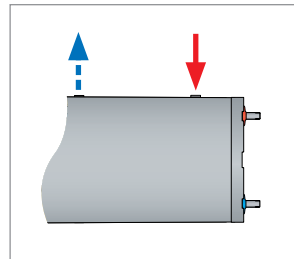

Horizontal installation
on a wall

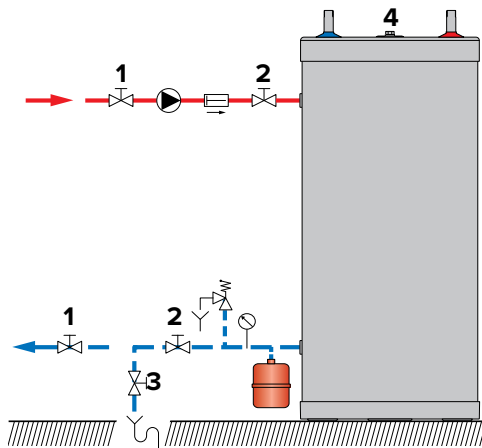

Figure 2

CHECKS BEFORE STARTING UP

- Check that the safety valves (DHW and primary) are correctly installed and that the outlets are connected to the sewer.
- Check that the DHW tank and the primary circuit are filled with water.
- Check that the air has been correctly bled from both circuits.
- Check that the tank's upper air bleed valve is tight.
- Check that the water side and heat source side pipes are correctly connected and not leaking.

STARTING UP PROCEDURE



To put the heating system into service, refer to the heating boiler manual.

PERIODIC CHECKS BY THE USER

- Check the pressure of the primary circuit pressure gauge: it should be between 0.5 and 1.5 bar.
- Visually inspect, on a regular basis, the valves, connections and accessories in order to detect any leaks or malfunction.
- Periodically check the air bleed valve located on the tank top to ensure that it is not leaking.
- Check that the DHW water circuit safety valves are in good operating condition.
- In the event of a problem, please contact an engineer or your installer.

ANNUAL MAINTENANCE



Essential instructions for the correct operation of the appliance

- The discharge pipe of the safety unit must be open to the outside. If the safety unit drips periodically, it may be due to an expansion problem or clogging of the valve.
- For internal inspections, the hand hole can be used. If there is none, use one of the water connections to insert the appropriate inspection equipment. If necessary, drain the tank before inspection.

The annual maintenance service, performed by an engineer, must include:

- A check of the air bleed valve: the bleeding of air can lead to the need for adding water to the system.
- A check of the primary and DHW circuit pressure gauges.
- The manual activation of the storage water circuit safety valve once a year. This operation will lead to a discharge of hot water.
- A check of the correct operation of valves, taps, control units and accessories that are possibly installed [refer to the manufacturer's instructions if necessary].

DRAINING



Essential instruction for the safety of persons and the environment

- The water coming out of the drain valve is very hot and can cause very severe burns. Make sure the area around the hot water flow is clear of people.



Essential instruction for the electrical safety

- Shut down the external electrical supply of the appliance before draining.



Essential instructions for the correct operation of the system

- Drain the tank if it is not used in winter and is at risk from exposure to ice. If the primary circuit water contains antifreeze, only the DHW tank must be drained. If the heating circuit does not contain antifreeze, the heating circuit and domestic water must be drained.
- Before draining the DHW, isolate the tank and lower the pressure of the heating circuit to 1 bar, in order to prevent the DHW tank from being crushed.

DRAINING THE PRIMARY CIRCUIT (Figure 3)

To drain the primary circuit of the hot water heater:

1. Stop the charging pump.
2. Isolate the primary circuit by closing the stop valves (1).
3. Connect the drain valve (2) to the sewer using a flexible hose.
4. Open the drain valve (2) and drain the water from the primary circuit to the drain.
5. Open the tank's air bleed valve (3) to accelerate drainage.
6. Close the drain valve (2) and air bleed valve (3) after draining the tank.

DRAINING THE DHW TANK (Figure 4)

To drain the hot water heater's DHW tank:

1. Open fully the hot water tap (3) for at least 60 minutes to make sure the DHW tank has cooled down sufficiently.
2. Close the filling valve (1) and the stop valve (4).
3. Connect the drain valve (2) to the sewer using a flexible hose.
4. Open the drain valve (2) and drain the water from the DHW tank to the sewer.
5. To accelerate the tank's drainage, open a hot water tap located higher than the tank connection in the DHW circuit.
6. Close the drain valve (2) and the hot water tap (3) after having drained the DHW tank.

BRINGING BACK INTO SERVICE AFTER MAINTENANCE

Refer to "Starting Up procedure", page 26.

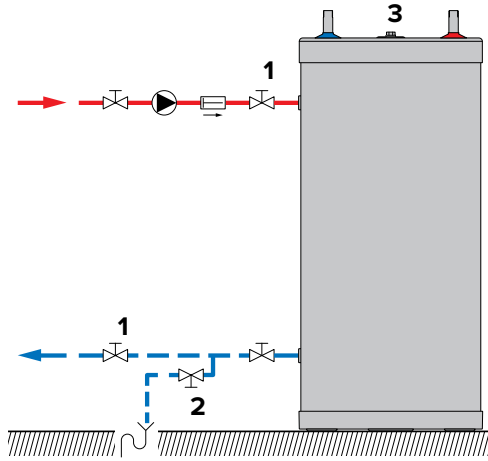
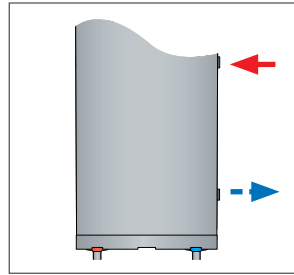
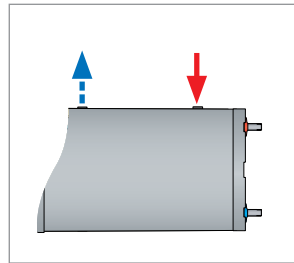

Figure 3

— Cold water
— Hot water



Vertical installation on a wall



Horizontal installation on a wall

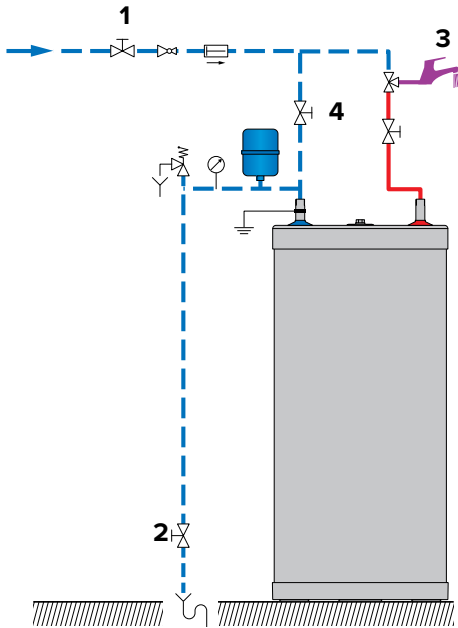
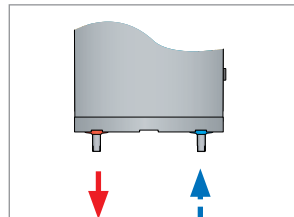
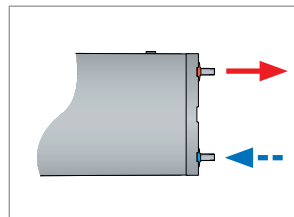

Figure 4



Vertical installation on a wall



Horizontal installation on a wall

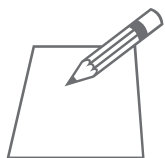

A series of horizontal dotted lines for writing, starting from the top right of the notepad illustration and extending across the page.



Handwriting practice lines consisting of a solid top line, a dashed middle line, and a solid bottom line. There are 20 such sets of lines on the page.

